

SUBJECT:

SERVICE INSTRUCTIONS—AUTRONIC-EYE® Automatic Headlight Control 12 VOLT—1955—CIRCUIT D

Shown herewith is general Car Application Data for the GUIDE Autronic-Eye automatic headlight beam control. Listed are the vehicles, model year, and part numbers. Also note serial numbers for the Amplifier and Phototube Units. For replacement parts see pages 21 and 22.

Car	Year	Amplifier and Phototube Unit Serial Numbers	Amplifier Unit ¹ Less Wiring	Amplifier Wiring Assembly	Phototube Unit ²	Power Relay	Auxiliary Foot Switch
CADILLAC—All	1955	From 555100001 Thru 555999999	5946698*	5946603	897871*	5946545	5945230
OLDSMOBILE							
Metal Panel	1955	From 355100001	5946697 ³	5946572*	897868 ⁴	5946545	5943291
Crash Pad Panel	1955	{355100001 Thru 355999999	5946697 ³	5946572*	897867 ⁴	5946545	5943291

¹For air conditioned cars use amplifier wiring assembly 5946605.

²Service replacement amplifier and phototube units will start with Serial 755510001 to 755599999 inclusive.

³Service replacement amplifier and phototube units will start with Serial 755310001 to 755399999 inclusive.

⁴Patent Nos. 2598420 and 2679616. Other Patents Pending.

THE AUTRONIC-EYE

The Autronic-Eye is an electronic device that automatically switches the headlamps between the upper and lower beams on the car to which it is installed, in response to light from an approaching car. It consists of four individual units: Phototube Unit, Amplifier Unit, Power Relay, and Auxiliary Foot Switch. (See Fig. 1)

The Phototube Unit is an optical device containing a phototube and receives power from the Amplifier Unit by cable. The lens of the Phototube Unit picks up light from approaching headlamps and focuses it through a filter and mask to the phototube within the unit. This light is then converted into an electrical signal and returned by cable to the Amplifier Unit. The Phototube Unit is mounted on the top left side of the instrument panel. The sensitivity of the Phototube Unit is adjusted to accommodate the clear or tinted windshields on the car to which it is installed. The mounting bracket will fit only the instrument panel of the car for which it is designed.

The Amplifier Unit is an electronic device which applies voltage to the Phototube Unit and the Power Relay. The Amplifier Unit operates the Power Relay in response to a signal from the Phototube Unit caused by the headlamps from an approaching car. The Amplifier Unit is mounted under the hood. The serial number is stamped on the end of the base.

The Power Relay, mounted under the hood, is a heavy duty relay, with special alloy contacts, for

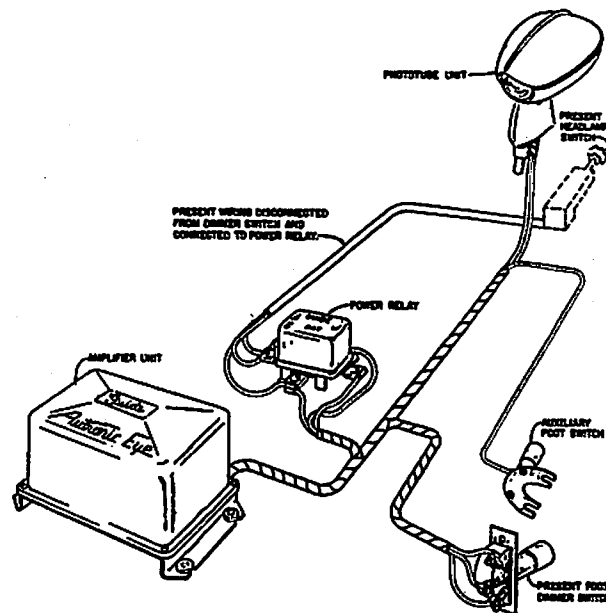

FIG. 1

switching the headlamps between the upper and lower beams.

The Auxiliary Foot Switch is a normally open, plunger type switch which is mounted on the toe pan near the Standard Foot Dimmer Switch. When the Autronic-Eye is controlling the headlamps, the Auxiliary Foot Switch when depressed and held in closed position provides an upper beam regardless of light on the Phototube Unit.

FUNCTIONAL OPERATION

The headlamps are controlled automatically in only one position of the Standard Foot Dimmer Switch. The other position of the Standard Foot Dimmer Switch is for the lower beam.

The Autronic-Eye is disconnected from its vehicle headlamps in the "Lower Beam" position of the Standard Foot Dimmer Switch; however, the Autronic-Eye is not turned off. It continues to function as long as the headlamps are turned on, and is ready at all times to provide automatic control whenever the Standard Foot Dimmer Switch is returned to the "Automatic" position.

The Auxiliary Foot Switch functions only in

the "Automatic" position of the Standard Foot Dimmer Switch. When depressed and held in closed position provides the upper beam regardless of light on the Phototube Unit. This arrangement permits signalling if desired and provides a simple test for the "Automatic" position of the Standard Foot Dimmer Switch.

5945230 Switch (Cadillac) mounts adjacent to standard foot dimmer switch. For test purposes depress only to closed position.)

5943291 Switch (Oldsmobile) mounts approximately 4 inches from standard foot dimmer switch. (For test purposes depress to bottom of stroke.)

BLOCK DIAGRAM

The battery supplies voltage through the ballast tube to the vibrator transformer. The vibrator transformer supplies voltage for the amplifier

stage and the phototube. When light strikes the phototube, a signal is transmitted to the amplifier stage which operates the Power Relay to switch headlamps between upper and lower beam.

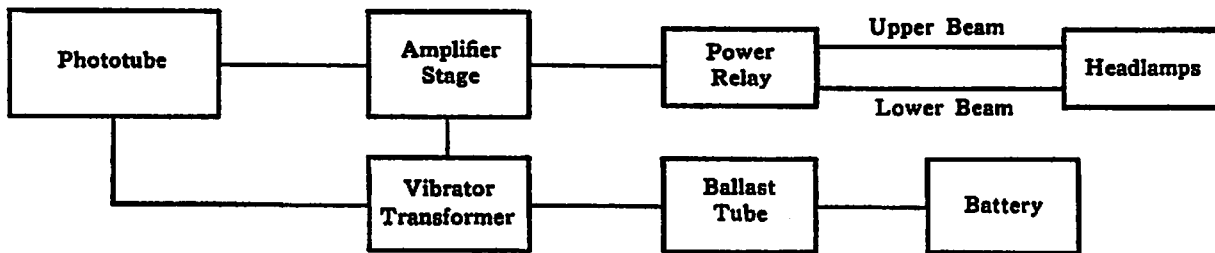

CIRCUIT DESCRIPTION

As shown in figure 2, page 3, supply voltage for the Autronic-Eye is received from the main light switch through the standard car wiring harness. This voltage is applied through the blue wire and the ballast tube to the primary winding of the transformer. Rheostat (17) is adjusted to produce the correct voltage at transformer center tap. One heater section of the amplifier tube is also connected to the ballast tube to limit surge peak voltage on the phototube during warm-up. The transformer has two secondary windings, one producing approximately 800 volts A.C. across resistor network (19, 11, 12) and the other approximately 150 volts A.C. Hold control (19) in the Amplifier Unit adjusts the voltage applied to the Phototube Unit.

The 150 volt winding is used as the power supply for the amplifier tube and sensitive relay. When the Standard Foot Dimmer Switch is in the "Automatic" position, the sensitive relay operates the power relay which in turn switches the headlamps between upper and lower beam. When the Standard Foot Dimmer Switch is in the "Lower Beam" position, the power relay will be energized, holding the headlamps on a lower beam.

When light strikes the Phototube Unit, current flows from the phototube to the control grid (G1)

of the amplifier tube. The control grid regulates the current flow through the amplifier tube. The voltage of the control grid is varied by the flow of current from the Phototube Unit to ground through resistor (10) and dim control (18) connected in parallel in the closed position of the sensitive relay contact points. In the open position of the sensitive relay, the flow of current from the phototube passes only through resistor (10) to ground. The combined total resistance value of resistor (10) and dim control (18) connected in parallel in the closed position of the sensitive relay is much less than the resistance value of resistor (10) alone, in the open position of the sensitive relay. Therefore, a given flow of current from the Phototube Unit produces a smaller voltage change at the control grid (G1) of the Amplifier Tube when the sensitive relay is closed compared to when it is open. When no current flows from the Phototube Unit, there is no voltage change across the resistor (10) or dim control (18), so the control grid is at the same voltage as its cathode because they are connected together. In this condition, section (1) of amplifier tube will conduct current and cause sensitive relay to be closed. The A.C. voltage is applied to the Phototube Unit in such a manner that any flow of current from the Phototube Unit through resistor (10) or dim control (18) is in a direction to pro-

(Please turn to Page 4)

CIRCUIT DIAGRAM AND MISCELLANEOUS DATA

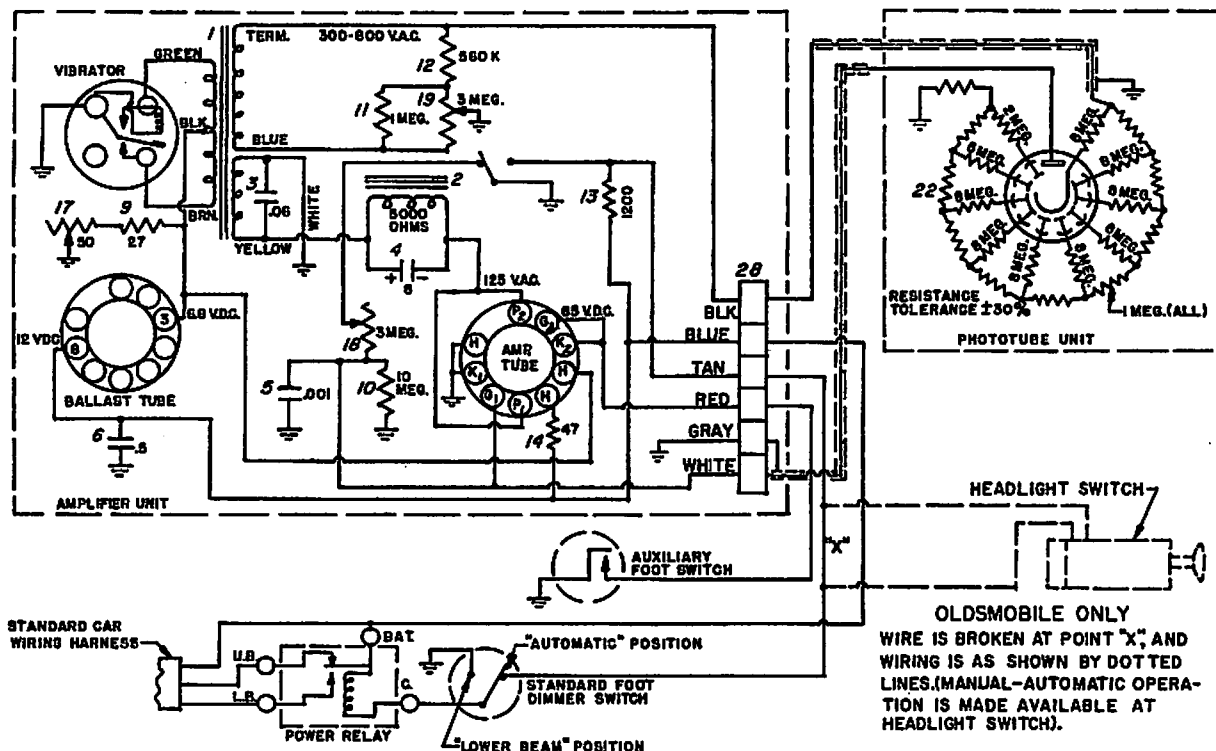

ALL AMPLIFIER VOLTAGES ARE MEASURED WITH PHOTOTUBE DISCONNECTED. ALL VOLTAGES ARE MEASURED FROM TERMINALS TO CHASSIS (EXCEPT WHERE STATED OTHERWISE) WITH A 20,000 OHM PER VOLT D.C. VOLTMETER AND A 1,000 OHM PER VOLT A.C. VOLTMETER. TOLERANCE ON VOLTAGES $\pm 10\%$. REFERENCE NUMBER ABOVE OR TO LEFT, AND VALUE BELOW OR TO RIGHT OF COMPONENTS. TUBE SOCKETS ARE VIEWED FROM TERMINAL SIDE.

TUBE LOCATION AND DISCONNECT BLOCK COLOR CODE (VIEWED FROM TERMINAL SIDE OF TUBE SOCKETS)

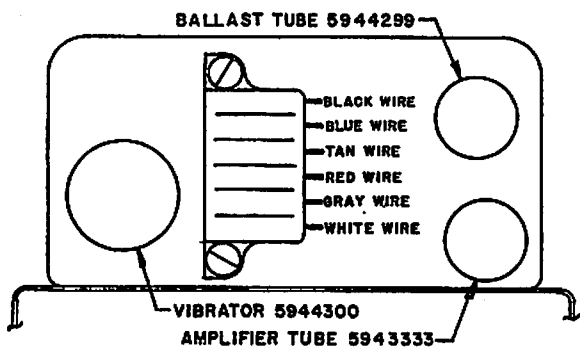

TRANSFORMER DATA

CODE	VOLTS	RESISTANCE
TERMINAL TO BLUE	800 V.A.C.	2200 OHMS
WHITE TO YELLOW	125 +V.A.C.	200 OHMS
BLACK TO GREEN	6.8 V.D.C.	0.5 OHM
BLACK TO BROWN	6.8 VDC	0.5 OHM

SENSITIVE RELAY COIL

UPPER BEAM	LOWER BEAM	RESISTANCE
25-40 V.D.C.	0 V.D.C.	5,000 OHMS $\pm 10\%$

POWER RELAY COIL

VOLTS	COIL RESISTANCE
12 V.D.C.	60 OHMS

FIG. 2

CIRCUIT DESCRIPTION (Continued)

duce a negative voltage change at the control grid (G1) of the amplifier tube. A small amount of current flowing from the Phototube Unit to ground through resistor (10), and dim control (18), produces a small negative voltage at the control grid (G1) causing the current through the sensitive relay to be reduced. An increase in current from the Phototube Unit causes the current through the sensitive relay to be further reduced until the relay opens. When the relay opens, current from the Phototube Unit passes through resistor (10) only and may be greatly reduced before the control grid (G1) loses its negative voltage to the point where section (1) of the amplifier tube passes enough current to close the sensitive relay again.

A small smoothing capacitor (5) is connected between the control grid (G1) and ground to reduce the voltage ripple at the grid. A capacitor (4) is connected across the coil of the sensitive relay to smooth the current flow through it. A

second triode section of the amplifier tube is connected between the sensitive relay and through the Auxiliary Foot Switch to ground. The control grid (G2) is connected directly to the cathode (K2) so that section (2) will pass current to close sensitive relay whenever the Auxiliary Foot Switch is closed. A capacitor (3) is connected across the 150 volt secondary winding of the transformer to protect vibrator. Resistor (13) is connected from the sensitive relay upper contact to the supply voltage to protect the points of the sensitive relay. Current in the Phototube Unit flows from the high voltage supply through the resistor network (22) to ground. Resistor network (22) divides the voltage evenly for each dynode of a multiplier type phototube. Each dynode is connected to the resistor network (22) through a protective resistor. The multiplier phototube passes current to the Amplifier Unit in response to light. No current flows when the phototube is dark.

ADJUSTMENTS

The Autronic-Eye is adjusted at the factory and should hold its adjustment over a long period of time. However, there may be occasions when the aiming or the sensitivity controls may require adjustment. These adjustments are made by using

Guide Autronic-Eye Tester Model AE manufactured by Sun Electric Corp. or Model 10 manufactured by Kent-Moore Organization, Inc. Use the following instructions for aiming and adjustment.

ADAPTOR RING AND AIMING DEVICE No. 4

In order that the above testers may be used in the round lens models, an adaptor ring and aiming device No. 4 has been made available through the manufacturers of the testers. The correct aim and sensitivity adjustments cannot be obtained on the round lens models without the use of this adaptor ring and aiming device.

As shown in Fig 3, place the widest side of the adaptor ring over the barrel of the test lamp and slide as far back as it will go against the square block of the test lamp. Rotate the ring until the center of the notch in the locating ring is in line with the center of the bottom of the test lamp. Tighten the set screw securely so the ring cannot

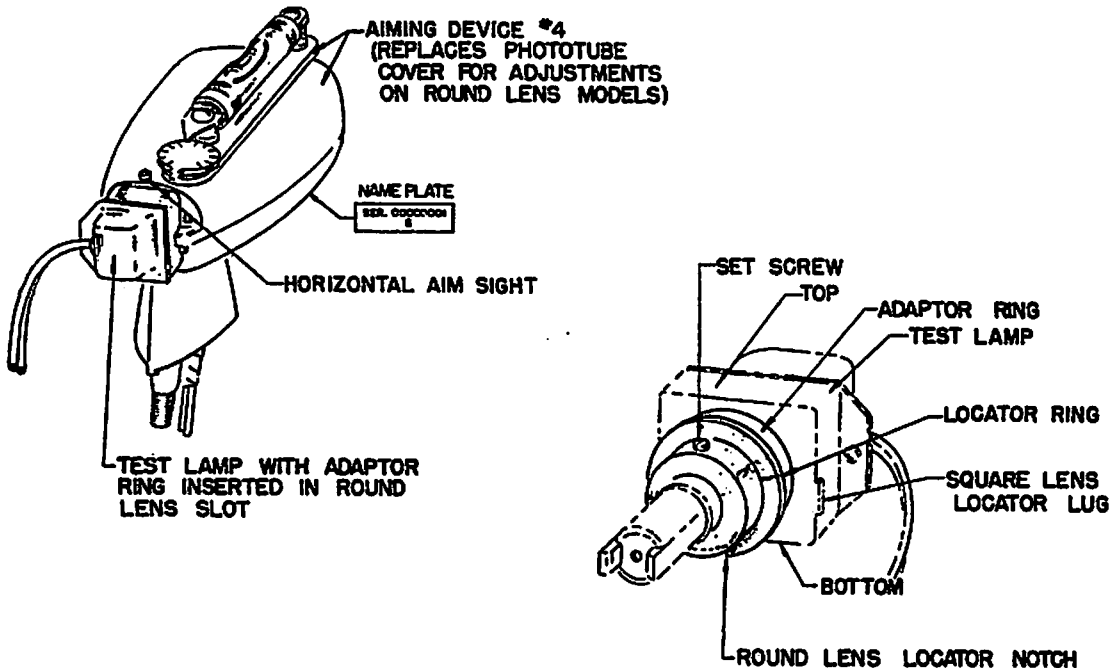

FIG. 3

ADAPTOR RING AND AIMING DEVICE No. 4 (Continued)

slip. THERE IS NO NEED TO REMOVE THE RING ONCE IT IS INSTALLED. When adjusting the square lens models, use the same locating lugs on the square block as before and the adaptor ring will be inside the phototube unit and out of the way.

The Aiming Device No. 4 consists of a special phototube unit cover with the leveling device mounted on it. Two horizontal aiming sights, located on the center line of the special phototube unit cover, are explained in the Horizontal Aiming Section, page 9. DO NOT USE THE SQUARE LENS AIMING DEVICE ON THE ROUND LENS MODELS.

To adjust the aim and sensitivity on the round lens models, remove the regular cover and lens from the phototube unit. Install the test lamp in

the base by inserting the locator ring in the lens slot. The lens locator in the phototube unit base must fit in the locator ring notch. Replace the regular cover with the new aiming device. Be sure the cover retaining screws are tightened securely. Follow the instructions for aiming and sensitivity adjustments on car.

CAUTION: The aiming device No. 4 contains a special filter to permit use of the same meter settings on the tester for round lens models as for square lens models. This filter should be kept free of dust and foreign particles. If filter is damaged the aiming device must be returned to tester manufacturer for repair. THIS FILTER DOES NOT REPLACE THE AMBER FILTER IN THE PHOTOTUBE UNIT WHICH MUST BE LEFT IN PLACE AS BEFORE.

VERTICAL AIM OF PHOTOTUBE UNIT

Proper performance of the automatic headlamp control requires that the Phototube Unit be accurately adjusted for both horizontal and vertical aiming. (Horizontal aiming procedure is explained on page 9.) Aimed too low, back reflections from headlamps of car on which the "Autronic-Eye" is installed will hold its own headlamps on low beam. However, unit must be aimed as low as possible to provide maximum tolerance for car loading.

IMPORTANT—Vertical aiming should be done with car unloaded, trunk empty except for spare tire, correct tire pressure and preferably with gas tank at least half full.

1. Locate car on level floor. Floor must be level within $\frac{1}{4}$ " fore and aft of car.
2. Rock car sideways to equalize springs.
3. Install AIMING DEVICE No. 4 according to instructions in Adaptor Ring and Aiming Device No. 4 Section.
4. Observe number stamped on name plate on bottom side of Phototube Unit and adjust dial of Aiming Device No. 4 to this number. (See Fig. 3.)
5. Adjust phototube aiming screw until bubble is centered in level using Allen wrench located inside tester cover.

SENSITIVITY TESTS AND ADJUSTMENTS ON CAR

HOLD SENSITIVITY TEST

Caution—The "Autronic-Eye" develops 800 volts. Turn headlamps OFF before removing cover from the phototube unit.

1. Install Aiming Device No. 4 according to instructions in Adaptor Ring and Aiming Device No. 4 Section.
2. Turn headlamps ON and wait at least four minutes for amplifier to stabilize. Set standard foot dimmer switch to "Automatic" position. NOTE—Oldsmobile headlamp switch provides "Manual" and "Automatic" control. Set this switch to "Automatic" position also. (Upper beam will then be on.)
3. Turn ZERO CORRECTOR on face of meter until meter pointer is on zero set line.
4. Turn INTENSITY RHEOSTAT of tester counter-clockwise.
5. When using Model AE, Sun Tester, insert tester CONNECTOR into cigar lighter receptacle (Caution—push straight in). The Model 10 Kent-Moore Tester contains its own power supply.
6. Check car battery voltage. If less than 12

volts operate engine at fast idle when making sensitivity tests and adjustments.

7. Turn SELECTOR or Dim-Hold Switch to "Dim" position. NOTE—Model AE Sun Tester provides a SELECTOR SWITCH for setting meter to proper Dim-Hold position for clear or tinted windshield. The Model 10 Kent-Moore tester provides a Dim-Hold switch and separate meter scales are provided for clear or tinted windshield.
8. Turn INTENSITY RHEOSTAT all the way clockwise to end of adjustment to obtain a lower beam.
9. Turn tester SELECTOR or Dim-Hold Switch to HOLD position.
10. Slowly turn INTENSITY RHEOSTAT counter-clockwise just to point where headlamps switch to upper beam. The meter pointer should now read in HOLD SENSITIVITY ADJUSTMENT BAR on the meter scale.

If HOLD Sensitivity is not properly adjusted, proceed with HOLD SENSITIVITY adjustment.

HOLD SENSITIVITY ADJUSTMENT

The Hold and Dim adjustments are knurled fingertip controls located on the bottom (outside) of the amplifier unit. The location of each is indicated by a stamp on the amplifier cover, (See Figure 4.) THE DIM SENSITIVITY ADJUSTMENT MUST NOT BE MADE UNTIL AFTER THE HOLD SENSITIVITY IS CORRECTLY ADJUSTED.

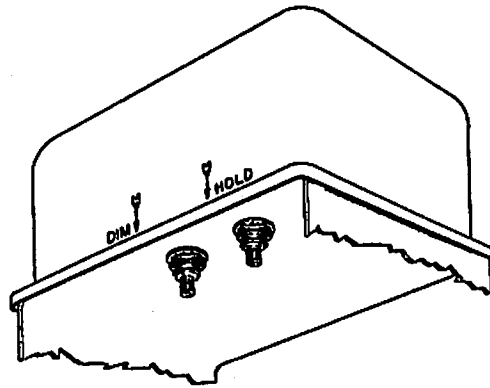

FIG. 4

1. Turn Hold Adjustment clockwise to end of adjustment.
2. Rotate INTENSITY RHEOSTAT all the way clockwise.
3. Turn SELECTOR or Dim-Hold Switch momentarily to DIM position to switch lights to lower beam, then switch back to HOLD position.

(NOTE—If lights do not switch to lower beam, the DIM control must be turned clockwise to end of adjustment and then readjusted after HOLD adjustment is correct.)

4. Adjust tester INTENSITY RHEOSTAT until meter pointer is in center of HOLD SENSITIVITY BAR.
5. Turn the Hold Control counter-clockwise slowly just to the point where headlamps switch to upper beam.

6. Rotate tester INTENSITY RHEOSTAT clockwise to end of travel, then turn SELECTOR or Dim-Hold Switch momentarily to DIM position and back to HOLD.
7. Recheck Hold adjustment by turning INTENSITY RHEOSTAT slowly counter-clockwise just to point where headlamps switch to upper beam. Meter pointer should now read in HOLD SENSITIVITY ADJUSTMENT BAR if adjustment is correct. If not repeat procedure starting with Step 1.

DIM SENSITIVITY TEST

1. Rotate tester INTENSITY RHEOSTAT completely counter-clockwise.
2. Turn SELECTOR OR DIM-HOLD Switch to DIM position. Headlamps should be on upper beam.
3. Turn INTENSITY RHEOSTAT slowly

clockwise stopping at the exact point where the headlamps switch to lower beam. Meter pointer should read within the DIM SENSITIVITY ADJUSTMENT LINE.

If Dim sensitivity is not properly adjusted proceed with Dim sensitivity adjustment.

DIM SENSITIVITY ADJUSTMENT

1. Rotate Dim control completely counter-clockwise. (See Figure 4.)
2. Momentarily turn tester off then back to dim position. Headlamps should now be on upper beam.
3. Adjust INTENSITY RHEOSTAT until meter pointer reads in the right hand edge of the DIM Sensitivity Adjustment Line.
4. Slowly rotate Dim control clockwise just to point where headlamps switch to lower beam. Do not go beyond this setting.
5. Turn tester INTENSITY RHEOSTAT completely counter-clockwise, then momentarily turn tester to OFF and back to DIM.
6. Rotate tester INTENSITY RHEOSTAT slowly clockwise just to point where headlamps switch to lower beam. Meter will read within DIM SENSITIVITY LINE if adjustment is correct. If not, repeat Step 1 thru 5.
7. Turn off headlights and disconnect tester from cigar lighter receptacle.
8. Remove tester and Aiming Device No. 4 from Phototube Unit. Replace lens cover and screws.

SENSITIVITY ADJUSTMENTS OFF CAR

The procedure for adjusting "DIM" sensitivity and "HOLD" sensitivity using the Autronic-Eye tester is the same for "on" and "off" the car. The Amplifier Unit and Phototube Unit should be connected when adjusting "off" the car as shown in Figure 5.

1. Connect a jumper wire between the black wire from phototube unit to corresponding wire in the amplifier disconnect block.
2. Connect a shielded jumper wire between white wire from the Phototube Unit to corresponding wire in the Amplifier disconnect block.

NOTE: As shown in Fig. 5 one end of the shield on the jumper wire must overlap the shield on the black wire from the Phototube Unit a few inches. The other end of the shield must extend as close to the end of the wire as possible and be grounded at the amplifier disconnect block.

Failure to comply with the above instructions will result in interaction between the black and white wires and cause misadjustment or locking on low beam.

3. Ground the phototube unit to the amplifier unit.
4. Connect the positive (+) side of a 12 volt battery to the blue wire in the amplifier disconnect block and ground the amplifier chassis to the negative side of the battery. Wait at least four minutes for warm up.

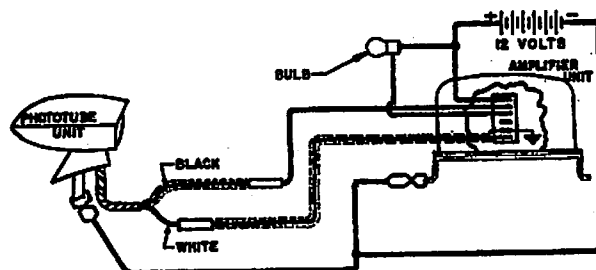

FIG. 5

5. When using Model AE, Sun Tester connect the positive side of the battery to the center terminal of the connector on the Sensitivity Tester and the negative side of the outer shell of the connector. The Model 10, Kent-Moore Tester contains its own power supply.
6. Connect a small indicator bulb between the tan wire in amplifier disconnect block and the positive (+) side of the 12 volt battery.
7. When the bulb lights, the headlamps on the car to which the Autronic-Eye was installed would have been on lower beam and when the bulb goes out, the headlamps would have been on upper beam.
8. For "DIM" and "HOLD" sensitivity adjustment, follow instructions for sensitivity adjustments on car.

INSTALLATION WIRING

If trouble is in the Phototube Unit or the Amplifier Unit, both should be removed from the car and serviced. If trouble is located in the Power Relay or the Auxiliary Foot Switch, the defective unit should be replaced. A disconnect block has been provided in the Amplifier Unit to allow the "Autronic-Eye" to be removed without removing the interconnecting harness from the car. **NOTE: IN AN EMERGENCY WHERE SERVICE IS NOT AVAILABLE, THE AUTRONIC-EYE SHOULD BE DISCONNECTED BY REMOVING THE SHORT BLUE AND TAN WIRES LEADING TO THE AMPLIFIER TUBE SOCKET FROM THE DISCONNECT BLOCK. THE CAR HEADLAMPS WILL THEN BE MANUAL CONTROLLED BY THE STANDARD FOOT DIMMER SWITCH.**

The following procedure should be followed in removing the Autronic-Eye from the car:

1. Remove Amplifier Cover.
2. Disconnect harness wires from disconnect block.
3. Remove Amplifier Unit mounting bolts.
4. Remove grommet and wiring harness from Amplifier base.

5. Remove Amplifier Unit from car.
6. Tape terminals on blue wire and tan wire. (Note: Must be insulated from the car frame.)
7. Disconnect the black and white wires under the dash.
8. Remove Phototube Unit from dash.

When the harness is removed from the Amplifier Unit, the car headlamps will revert to manual operation and will switch between upper and lower beam by operation of the Standard Foot Dimmer Switch. (Note: When Amplifier Unit is removed from the car, be sure the terminals on blue wire and tan wire in harness are insulated from the car frame.)

The interconnecting harness should be in accordance with wiring diagram. (See Fig. 6).

When reinstalling the Amplifier Unit, replace the harness and grommet in Amplifier base. (Be sure the grommet is properly seated in base.) Connect harness wires to disconnect block—matching wire colors with wires in Amplifier Unit.

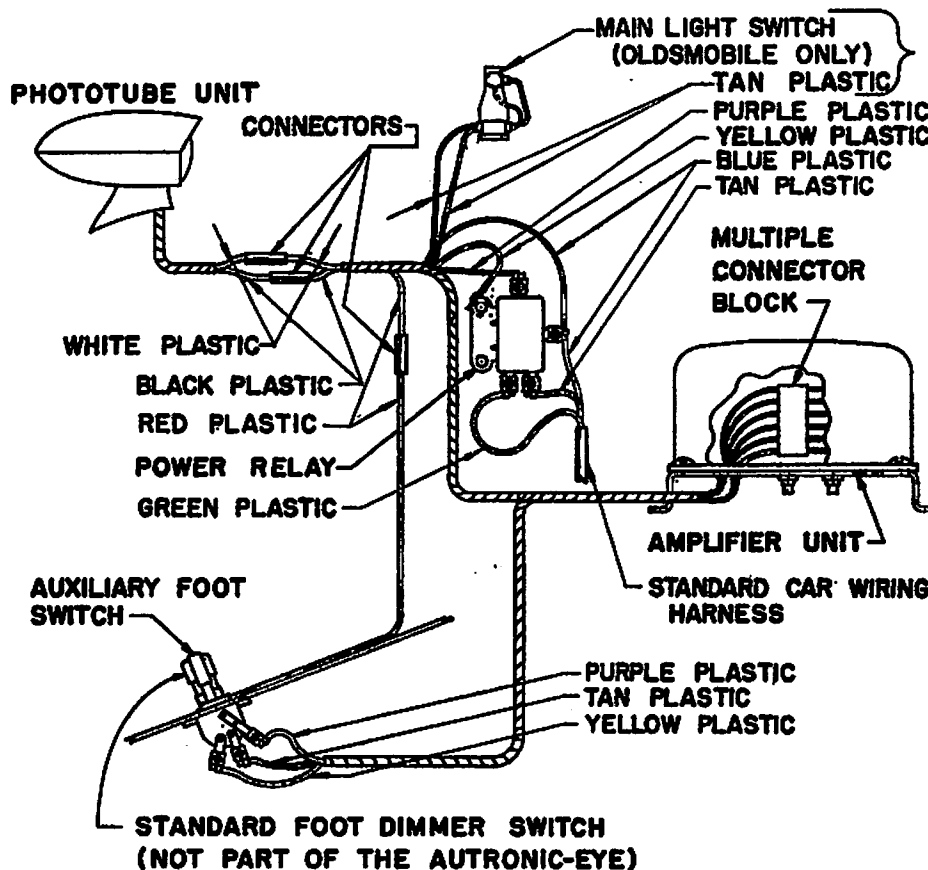

FIG. 6

HORIZONTAL AIM

When reinstalling the Phototube Unit, the locating pin on the rear of the mounting bracket must be properly mounted in the locating hole in car dash to provide the correct horizontal alignment. The centerline of the phototube unit must be aimed parallel to the horizontal centerline of the car. **Unsatisfactory Operation on Curved Highways Will Result If Horizontal Aim Is Incorrect.** The horizontal aim should be checked as follows: (See Fig. 7)

1. Locate the car approximately 25 feet from a vertical wall or screen.
2. Sight down the car hood and place a piece of tape on the wall at hood height to represent car centerline.
3. Measure distance between centerline of phototube and center of car windshield. Place a sec-

ond piece of tape this distance to the left of the car centerline.

4. One of the following two procedures may now be used.
 - (a) Sight along raised rib on Phototube Unit—should point at line established on wall to left of the car centerline.
 - (b) Replace cover of Phototube Unit with Aiming Device No. 4. Sight over top of two sights on the aiming device—should point at line established on wall to left of the car centerline.

If horizontal aim is not correct, remove the Phototube Unit from car dash and elongate one side of the mounting stud hole in the instrument panel sufficiently to rotate the unit for correct aim. Vertical aim must be checked after relocating Phototube Unit.

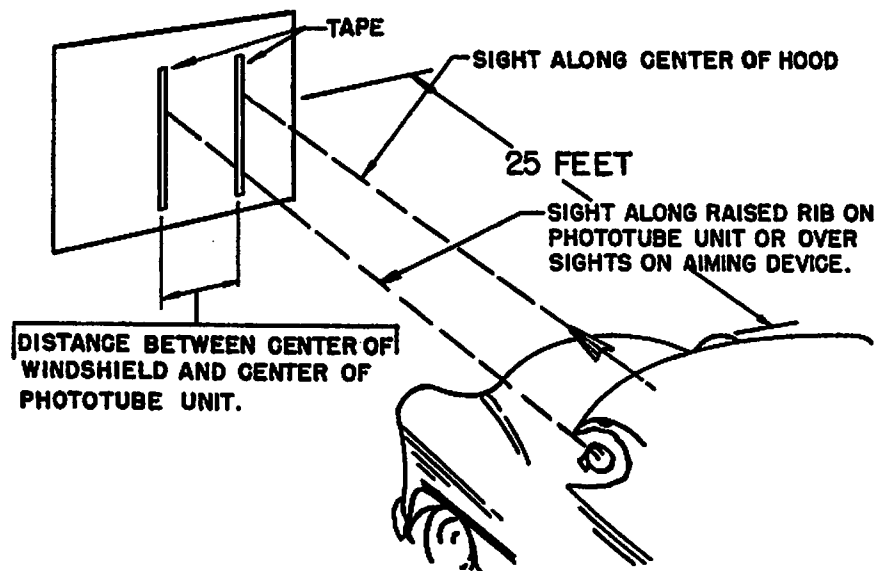
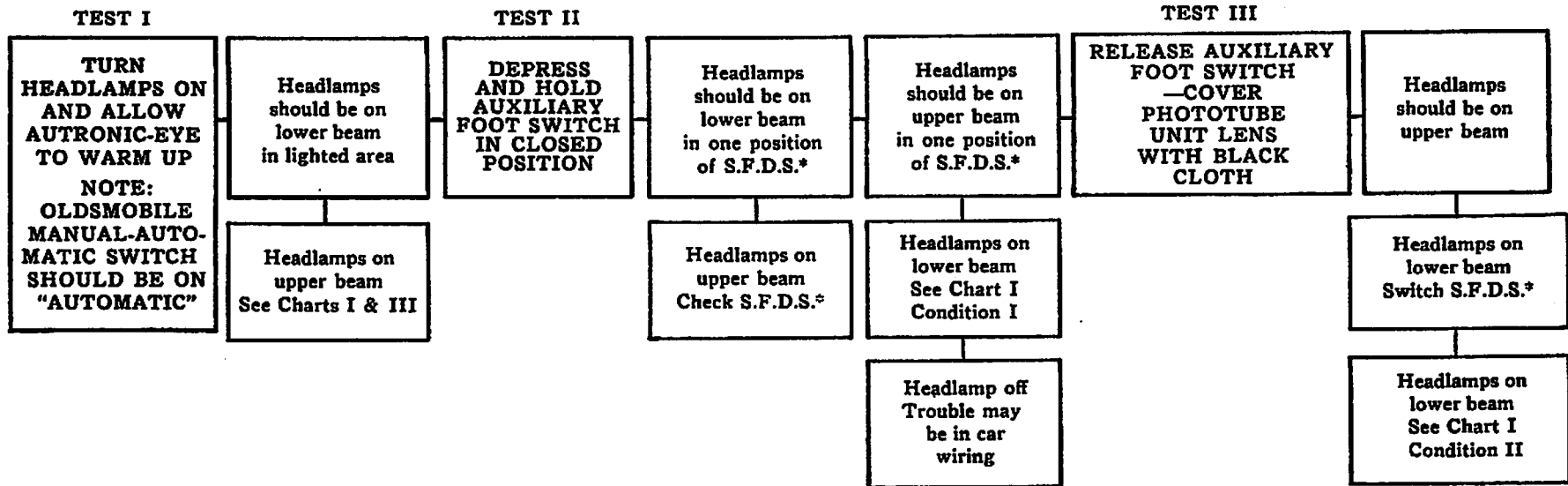

FIG. 7

OPERATION TESTS ON CAR

Note: Read the chart from LEFT to RIGHT until the specified condition does not apply to the Autronic-Eye being tested, then read down until the condition listed is identical to that of the Autronic-Eye under test. See the chart indicated for further analysis.



*S.F.D.S.—Standard Foot Dimmer Switch

INITIAL TROUBLE SHOOTING TESTS ON CAR

Note: Read the chart from LEFT to RIGHT until the specified condition does not apply to the Autronic-Eye being tested, then read down until the condition listed is identical to that of the Autronic-Eye under test. See the chart indicated for further analysis. CAUTION—HIGH VOLTAGE. HEADLAMPS SHOULD BE TURNED OFF BEFORE PROCEEDING FROM ONE TEST TO THE NEXT.

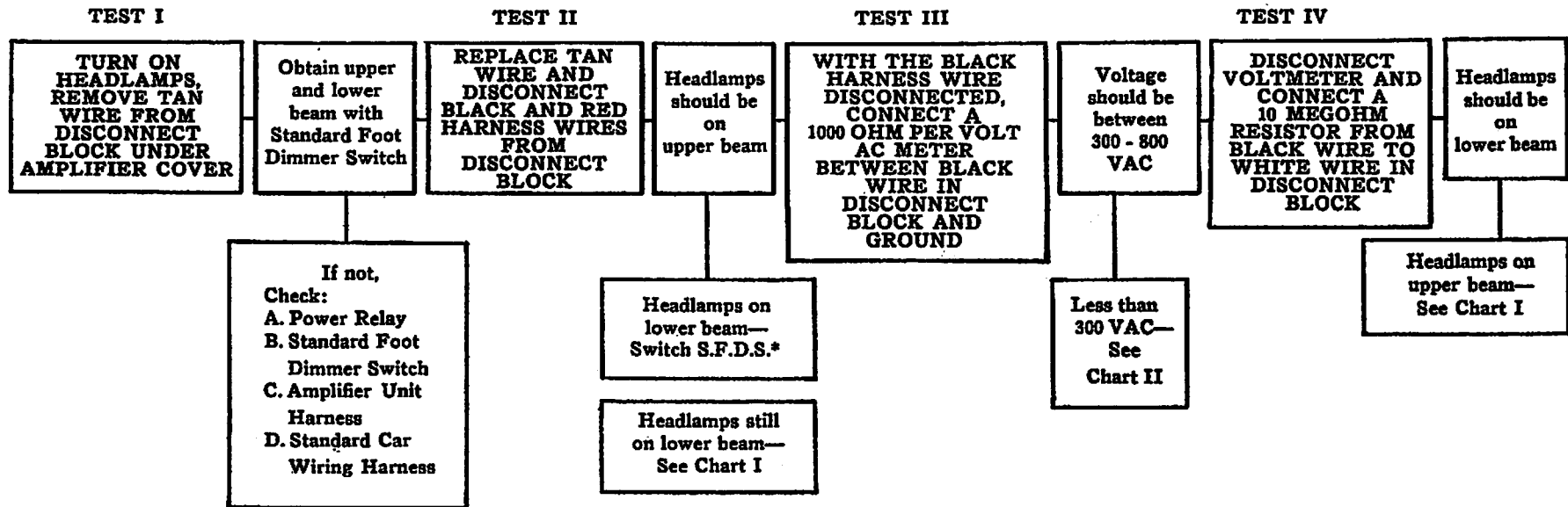

INITIAL PREPARATION FOR TEST:

1. Check tubes and vibrator (by substitution of known good part).
2. A.C. Voltage measured with 1000 ohm per volt voltmeter.

*S.F.D.S.—Standard Foot Dimmer Switch

INITIAL TROUBLE SHOOTING TESTS ON CAR—PAGE TWO

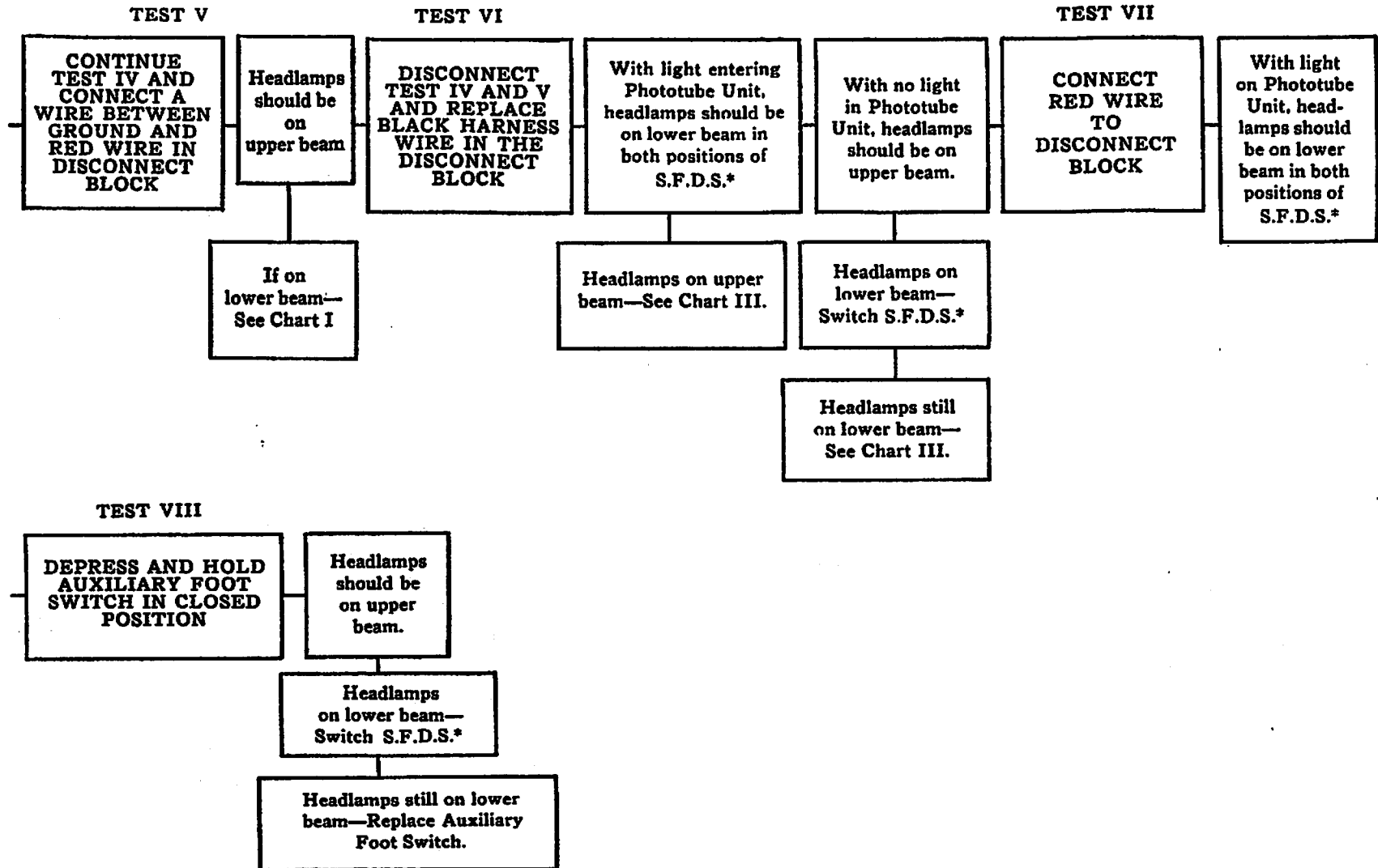

*S.F.D.S.—Standard Foot Dimmer Switch

INITIAL TROUBLE SHOOTING TEST OFF CAR

Note: Read the chart from LEFT to RIGHT until the specified condition does not apply to the Autronic-Eye being tested, then read down until the condition listed is identical to that of the Autronic-Eye under test. See the chart indicated for further analysis. CAUTION—HIGH VOLTAGE.

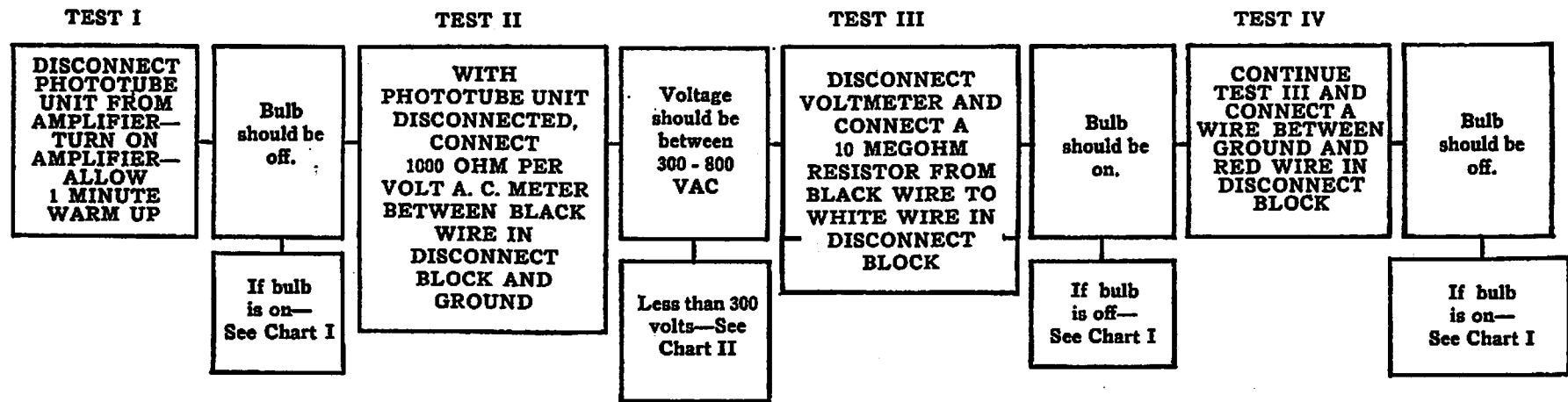

INITIAL PREPARATION FOR TEST:

1. Check tubes and vibrator (by substitution of known good part).
2. Connect small 12 volt indicator bulb between tan wire on amplifier disconnect block and ground.
3. Adjust input to 12 volts.
4. D.C. voltage measured with 20,000 ohm per volt voltmeter.
5. A.C. voltage measured with 1,000 ohm per volt voltmeter.

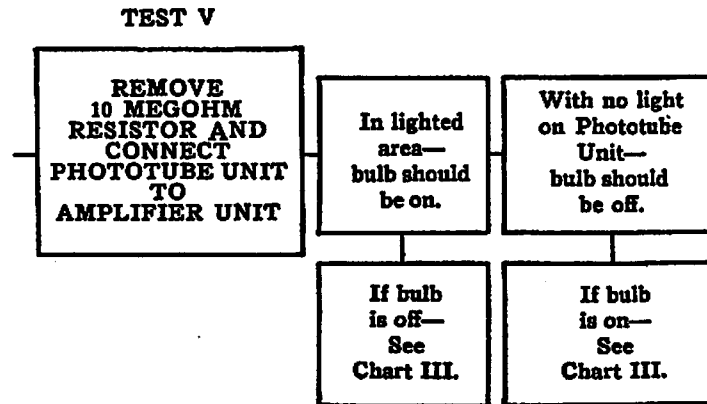
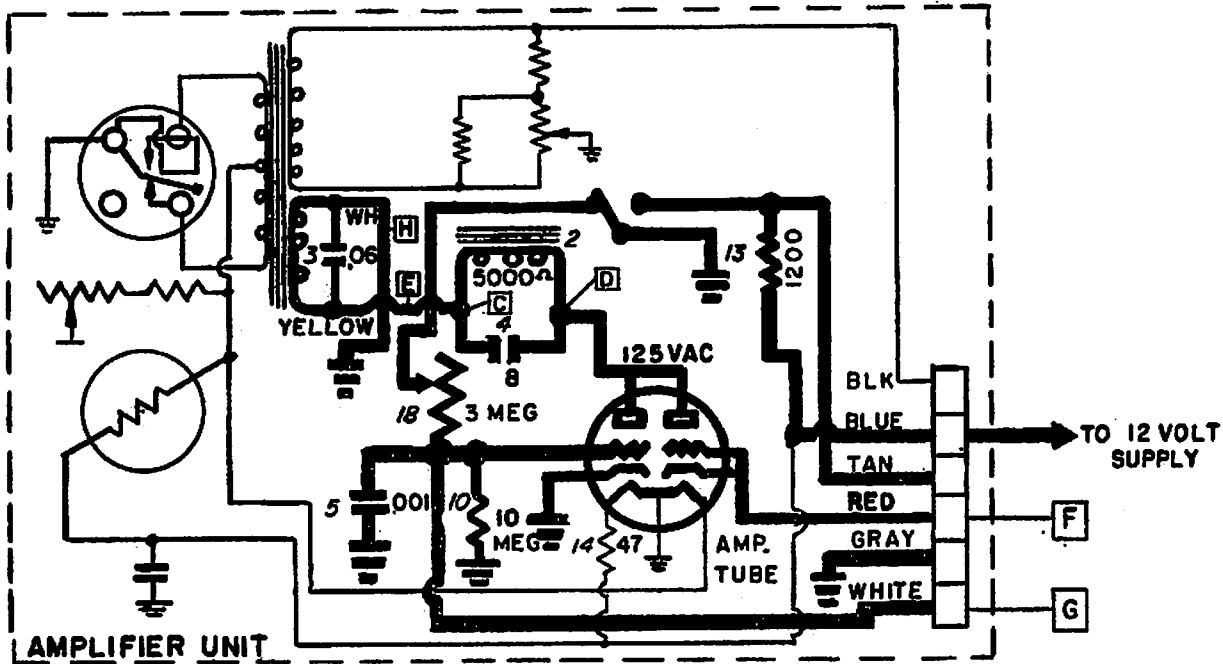

CHART I



CONDITION I: WITH PHOTOTUBE UNIT AND AUXILIARY FOOT SWITCH DISCONNECTED FROM AMPLIFIER UNIT, THE SENSITIVE RELAY IS CLOSED.

I. Turn amplifier off and connect 10 megohm resistor between black and white wires in amplifier disconnect block. Turn amplifier on and relay should be open.

IF
 Relay is open—Go to Check II.

IF
 1. If relay is closed check DIM control in amplifier. Must not be more than $\frac{3}{4}$ turn counter-clockwise or amplifier will keep headlamps on lower beam.
 2. Check continuity between [G] (White wire in amplifier disconnect block) and grid (pin 7) of the amplifier tube.

11. Continue Test I and ground [F] (red wire in amplifier disconnect block). Relay should be closed.

IF
 Relay is open, check
 1. Amplifier tube (by substitution).
 2. Continuity between [F] (red wire in amplifier disconnect block) and both grid and cathode (pins 2 and 3) of amplifier tube

CONDITION I (Continued)

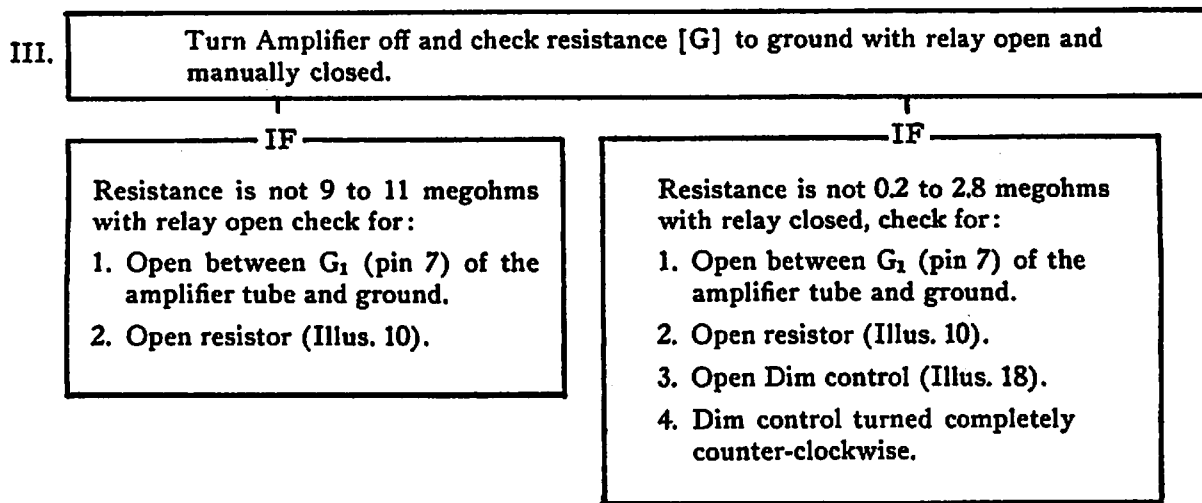

CONDITION II: WITH PHOTOTUBE UNIT AND AUXILIARY FOOT SWITCH DISCONNECTED FROM AMPLIFIER UNIT, THE SENSITIVE RELAY IS OPEN.

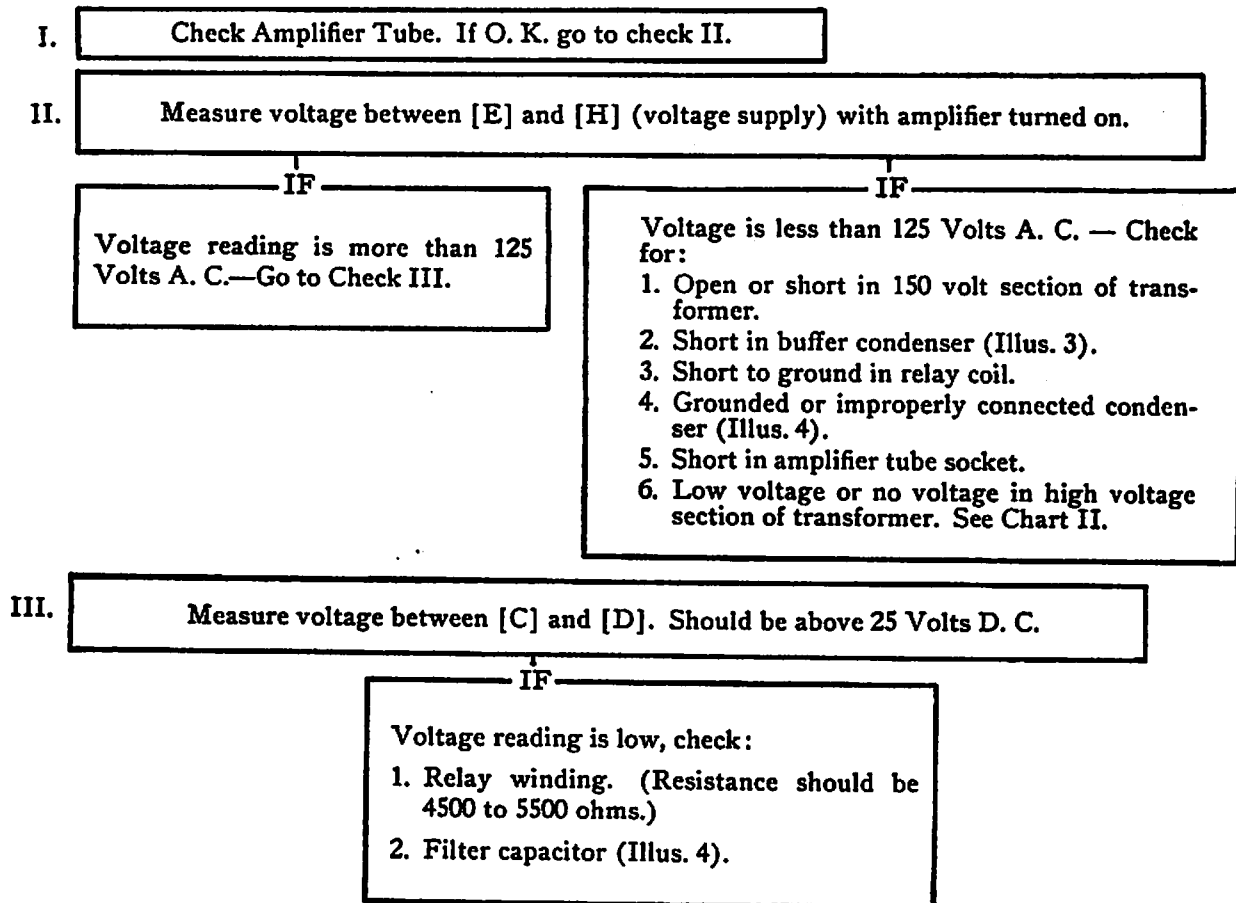
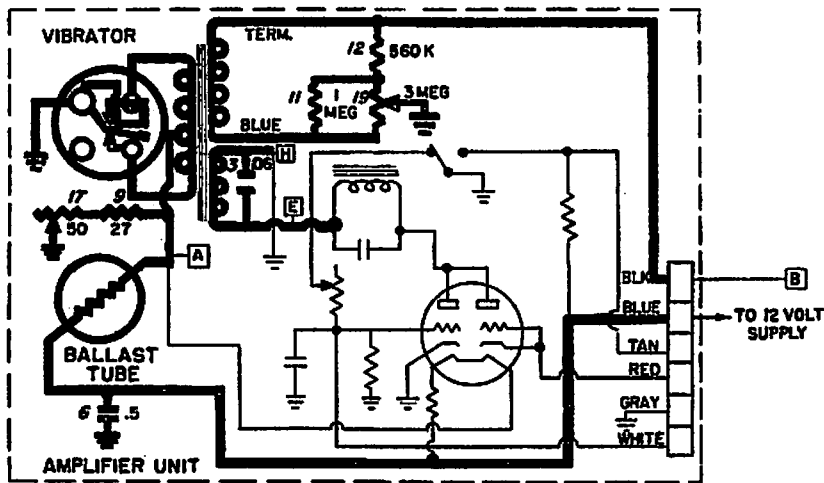

CHART II



NOTE: All voltage readings are obtained with Phototube Unit disconnected. The A.C. voltmeter must not be connected to [B] while measuring D.C. voltage at [A]. Otherwise readings at [A] will be in error by loading effect of A.C. voltmeter.

CONDITION I: THE A.C. VOLTAGE BETWEEN [B] (BLACK WIRE IN AMPLIFIER DISCONNECT BLOCK) AND GROUND IS INCORRECT. SHOULD BE BETWEEN 300 AND 800 VAC.

I. Measure voltage from (B) to ground. (Use 1000 ohm per volt AC meter.)

IF

VOLTAGE IS ZERO

Check for

1. Open ballast tube.
2. Open control (Illus. 19).
3. Shorted or open power transformer windings.
4. Defective vibrator.
5. Open in primary wiring.
6. Disconnected blue wire at disconnect block.

IF

VOLTAGE IS LOW

Check

1. Control (Illus. 19) adjustment.

IF

Adjustment will not correct voltage reading, measure voltage between Term. and blue wire should be approx. 800 VAC and measure voltage between (H) and (E) (should be above 125 VAC). If not, check:

1. For shorted transformer secondary winding.
2. Voltage between (A) and ground (should be approx. 6.8 VDC).

IF

VOLTAGE IS EXCESSIVELY HIGH

Check for

1. Open low voltage secondary winding.
2. Open load resistor (Illus. 12).

CHART III

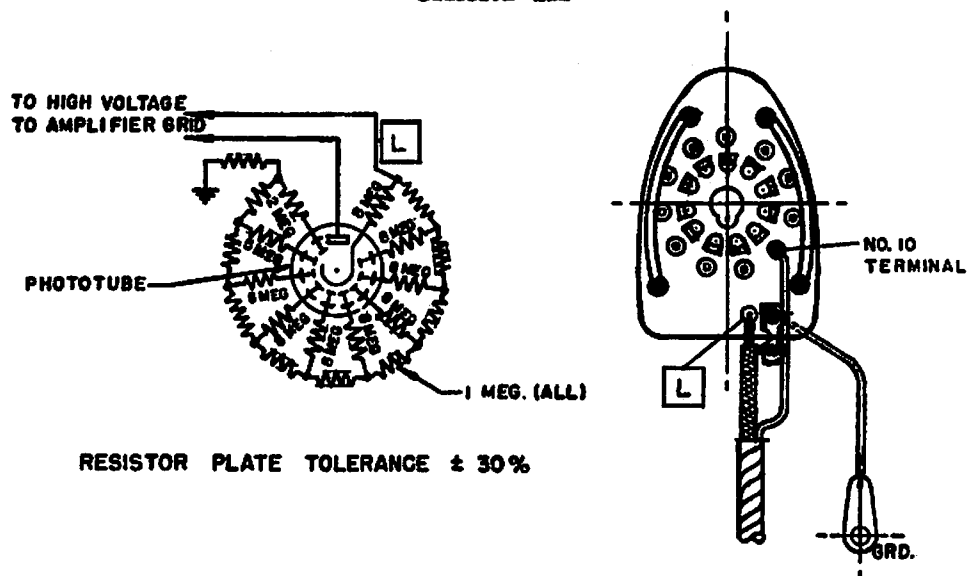

SOCKET, RESISTOR PLATE AND WIRE ASSEMBLY
 PRINTED NETWORK

CONDITION I: WITH PHOTOTUBE UNIT CONNECTED TO AMPLIFIER UNIT AND LIGHT ENTERING PHOTOTUBE UNIT, THE SENSITIVE RELAY IS CLOSED.

—CHECK FOR—

1. Defective socket and resistor plate assembly (Illus. 22) (disconnect phototube unit from amplifier unit and remove phototube from socket).
 - a. Resistance [L] to ground—should not exceed 20 megohms.
 - b. Resistance [L] to each tube socket contact except No. 10 (should be 5 to 20 megohms).
 - c. Resistance between adjoining contacts except No. 10 of phototube (should be 5 to 25 megohms).
2. Defective phototube (by substitution).

CONDITION II: WITH PHOTOTUBE UNIT CONNECTED TO AMPLIFIER UNIT AND NO LIGHT ENTERING THE PHOTOTUBE UNIT, THE SENSITIVE RELAY IS OPEN.

—CHECK FOR—

1. Defective phototube (by substitution).
2. Shorts of white wire in phototube unit.
3. Shorts of black wire in phototube unit.

CIRCUIT DIAGRAM AND MISCELLANEOUS DATA

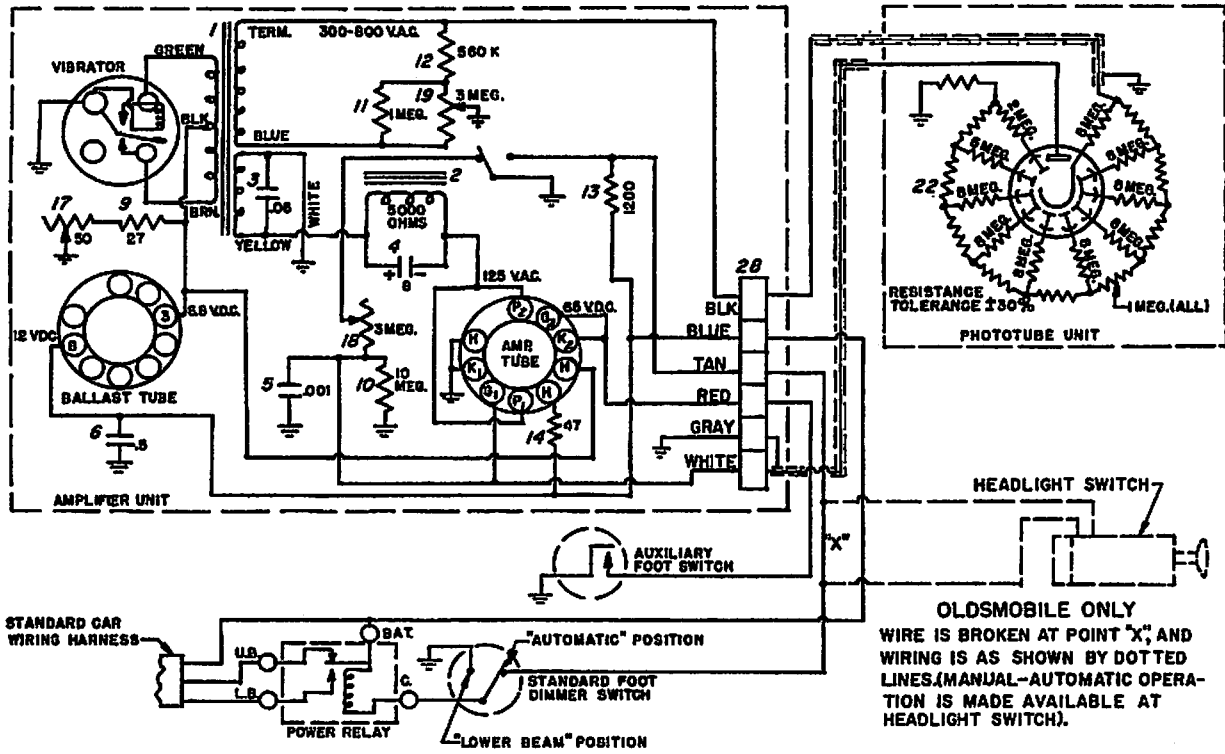

ALL AMPLIFIER VOLTAGES ARE MEASURED WITH PHOTOTUBE DISCONNECTED. ALL VOLTAGES ARE MEASURED FROM TERMINALS TO CHASSIS (EXCEPT WHERE STATED OTHERWISE) WITH A 20,000 OHM PER VOLT D.C. VOLT METER AND A 1,000 OHM PER VOLT A.C. VOLT METER. TOLERANCE ON VOLTAGES $\pm 10\%$. REFERENCE NUMBER ABOVE OR TO LEFT, AND VALUE BELOW OR TO RIGHT OF COMPONENTS. TUBE SOCKETS ARE VIEWED FROM TERMINAL SIDE.

TUBE LOCATION AND DISCONNECT BLOCK COLOR CODE (VIEWED FROM TERMINAL SIDE OF TUBE SOCKETS)

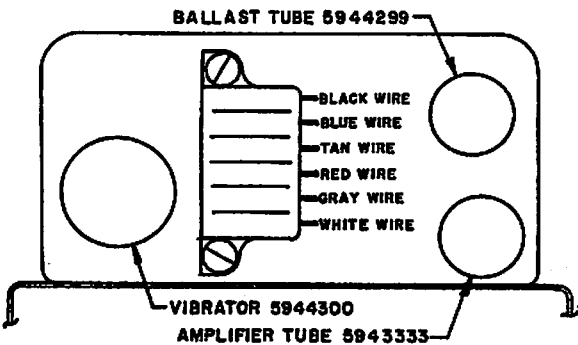

TRANSFORMER DATA

CODE	VOLTS	RESISTANCE
TERMINAL TO BLUE	800 V.A.C.	2200 OHMS
WHITE TO YELLOW	125 + V.A.C.	200 OHMS
BLACK TO GREEN	6.8 V.D.C.	0.5 OHM
BLACK TO BROWN	6.8 V.D.C.	0.5 OHM

SENSITIVE RELAY COIL

UPPER BEAM	LOWER BEAM	RESISTANCE
25-40 V.D.C.	0 V.D.C.	5,000 OHMS $\pm 10\%$

POWER RELAY COIL

VOLTS	COIL RESISTANCE
12 V.D.C.	60 OHMS

FIG. 2

AMPLIFIER UNIT PARTS LAYOUT (Back View)

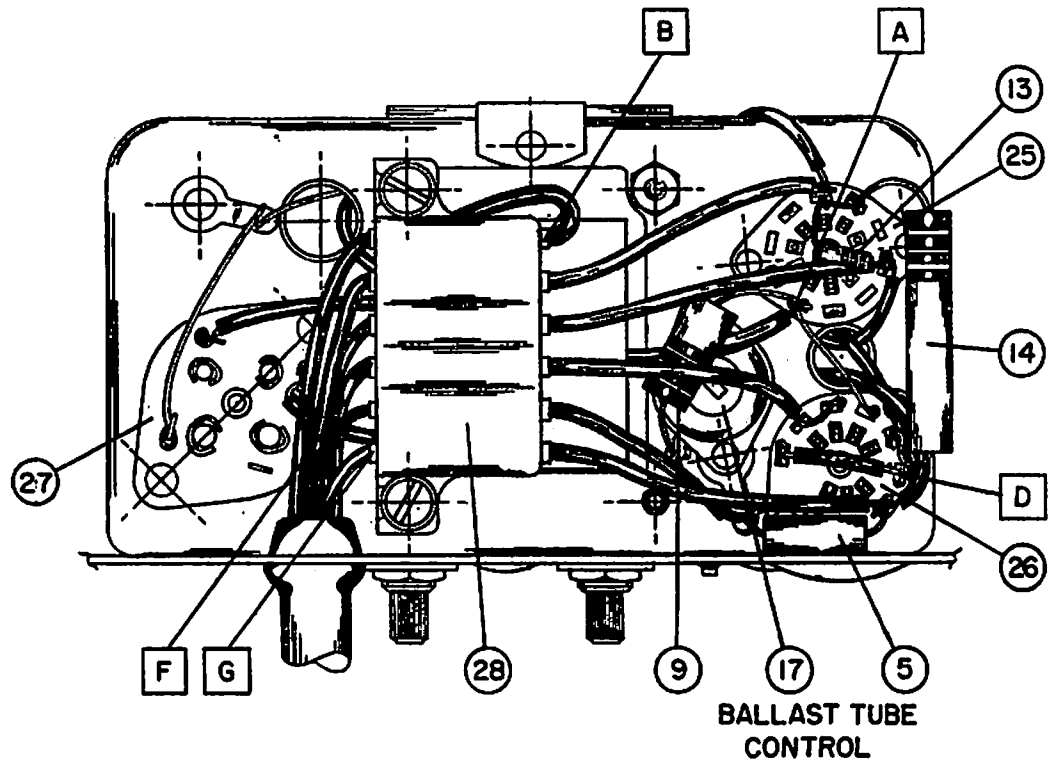

AMPLIFIER UNIT PARTS LAYOUT (Front View)

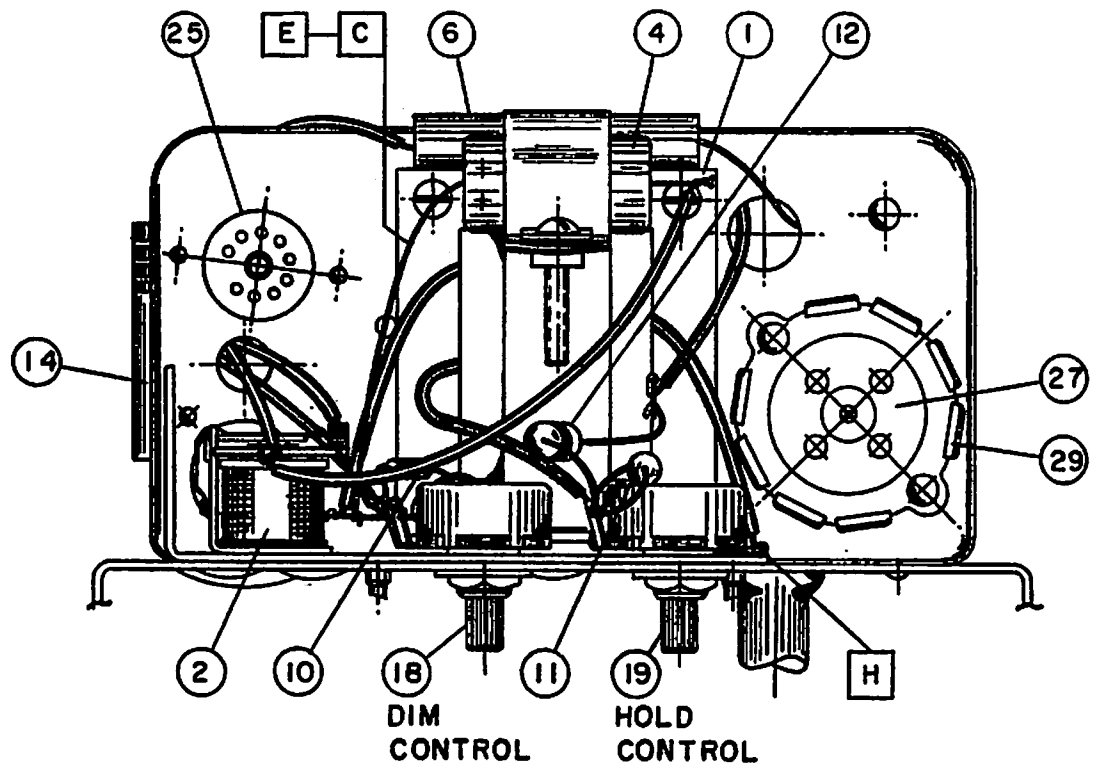

AMPLIFIER UNIT PARTS LAYOUT (End View)

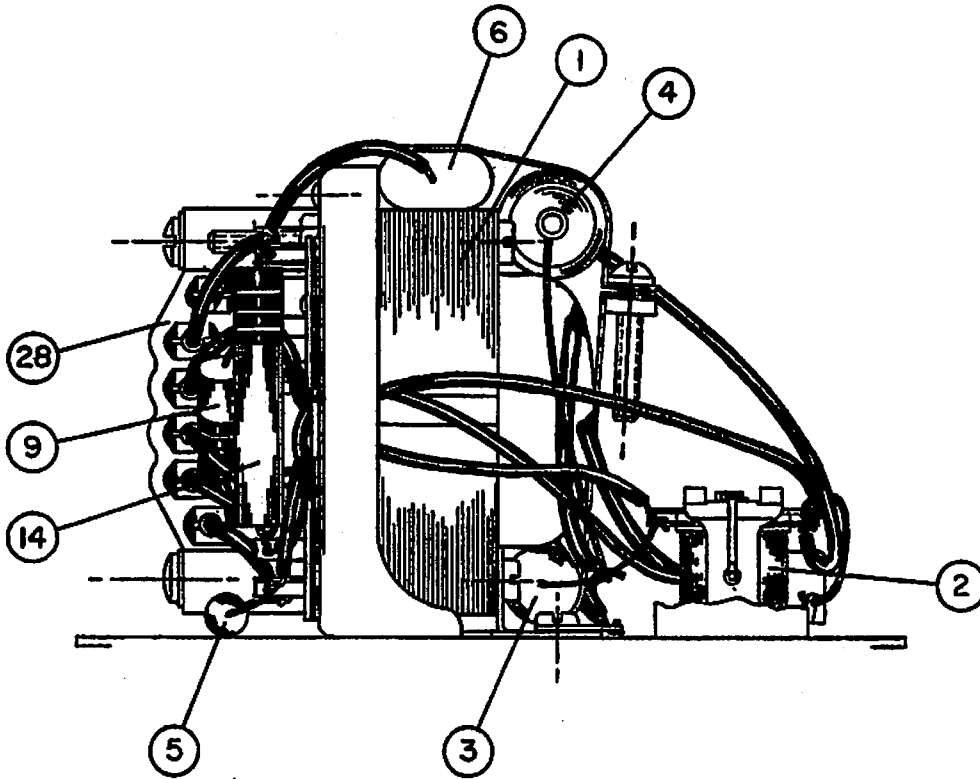

PHOTOTUBE UNIT PARTS LAYOUT

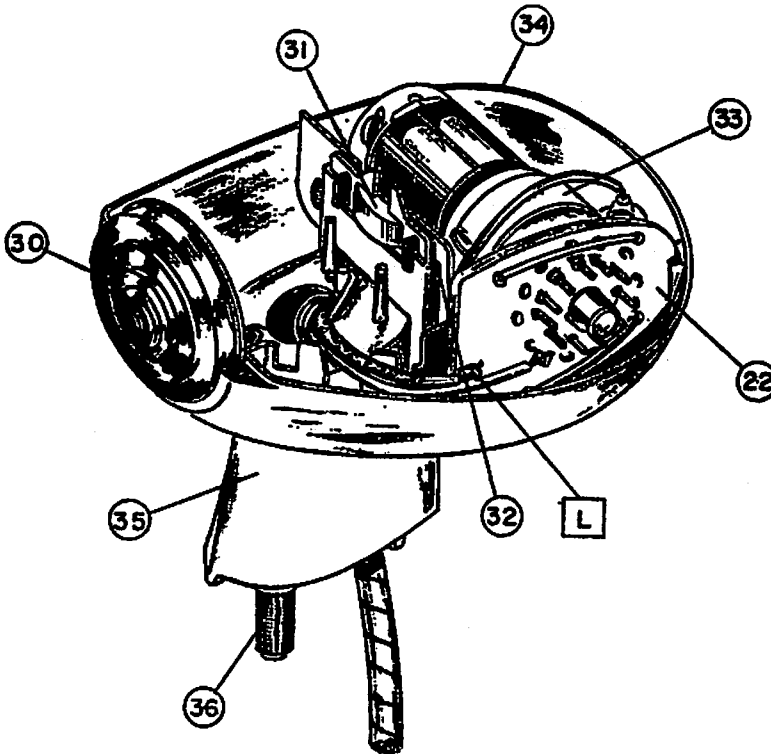

SERVICE PARTS LIST

Illustration No.	Production No.	Service Part No.	Description
ELECTRICAL PARTS FOR AMPLIFIER UNIT			
	5944300	5944300	Vibrator—Non-Synchronous
1	5946568	5946568	Transformer, Power
2	5946565	5946565	Relay, Sensitive
Capacitors			
3	5944296	5944296	.06 MFD 400 V. Tubular
4	5943323	5943323	8 MFD 50 V. Electrolytic
5	5946566	5946566	.001 MFD 200 V. Tubular
6	5943599	5943599	.5 MFD 25 V. Tubular
Resistors			
9	5944709	1180	27 OHMS 2W. Insulated
10	1215548	1247	10 MEGOHMS ½W. ± 10% Insulated
11	1220461	1275	1 MEGOHM 1W. ± 10% Insulated—(Prior to Serial Nos. 555200001 and 355200001)
11	1220640	1292	270,000 OHMS 2W. ± 10% Insulated—(Starting with Serial Nos. 555200001, 355200001 and 155200001)
12	1220617	1272	560,000 OHMS 1W. ± 10% Insulated—(Prior to Serial Nos. 555200001 and 355200001)
12	1220638	1290	180,000 OHMS 2W. ± 10% Insulated—(Starting with Serial Nos. 555200001, 355200001 and 155200001)
13	5945229	1126	1200 OHMS ½W. Insulated
14	5946574	5946574	47 OHMS 2W. ± 5% Insulated—(Discontinued, starting with Serial Nos. 555200001, 355200001, 155200001)
Controls			
17	5943297	5943297	50 OHMS W.W. Rheostat—Ballast Tube Control
18	5946564	5946564	3 MEGOHMS Potentiometer—Dim Control
19	5946564	5946564	3 MEGOHMS Potentiometer—Hold Control
Wiring Assemblies			
	5946572	5946572	Wire Assembly—Oldsmobile
	5946605	5946605	Wire Assembly—Air Conditioned Oldsmobile
	5946603	5946603	Wire Assembly—Cadillac
	5946885	5946885	Wire Assembly—Chevrolet, Buick, Pontiac
ELECTRICAL PARTS FOR PHOTOTUBE UNIT			
22	5946556	5946556	Socket, Resistor Plate and Wire Assembly
MISCELLANEOUS PARTS			
	5943291	5943291	Switch—Auxiliary Foot—Oldsmobile
	5945230	5945230	Switch—Auxiliary Foot—Cadillac, Chevrolet, Pontiac, Buick
	5946545	5946545	Relay Assembly, Power
TUBES			
	5943333	5943333	Tube—"Guide"—Amplifier
	5944299	5944299	Tube—"Guide"—Ballast
	5946558	5946558	Tube—"Guide"—Phototube
MECHANICAL PARTS FOR AMPLIFIER UNIT			
25	5944287	5944287	Socket—Miniature
26	5943432	6073	Socket—Miniature—9 Pin
27	7239125	6036	Socket—Vibrator
28	5945182	5945182	Disconnect Block (Bakelite)
	5945263	5945263	Barrel Nut (Disconnect Block)
	5943337	5943337	Gasket—Cover
29	5943308	5943308	Clamp—Vibrator Ground
	5944679	5944679	Resilient Mounting—Oldsmobile

SERVICE PARTS LIST (Continued)

Illustration No.	Production No.	Service Part No.	Description
MECHANICAL PARTS FOR PHOTOTUBE UNIT			
30	5942564	5942564	Lens
31	5946693	5946693	Filter
32	5943300	5943300	Mask
33	5943347	5943347	Clamp—Tube Retaining
	5942563	5942563	Cover—Oldsmobile (Dark Gray)
	5942789	5942789	Cover—Chevrolet, Pontiac, Buick (Dark Gray)
	5942798	5942798	Cover—Cadillac (Cumulus Gray)
34	5946553	5946553	Base—Oldsmobile (Dark Gray)
34	5946888	5946888	Base—Chevrolet, Pontiac, Buick (Dark Gray)
34	5946584	5946584	Base—Cadillac (Cumulus Gray)
35	5942648	5942648	Mounting Bracket Assembly—Oldsmobile—Metal Panel (Dark Gray)
35	5942627	5942627	Mounting Bracket Assembly—Oldsmobile—Crash Pad Panel (Dark Gray)
35	5945278	5945278	Mounting Bracket Assembly—Cadillac (Cumulus Gray)
35	5945264	5945264	Mounting Bracket Assembly—Chevrolet, Pontiac, Buick (Dark Gray)
36	5930825	5930825	Stud—Mounting Bracket—Oldsmobile and Cadillac
36	922195	922195	Stud—Mounting Bracket—Chevrolet, Pontiac, Buick
	5943349	5943349	Nut—Friction—Mounting Bracket
	5942644	5942644	Spring—Oldsmobile and Cadillac
	5943355	5943355	Spring—Chevrolet, Pontiac, Buick (for use with mounting bracket assembly 5945264 only)
	455970	455970	Screw—Set—Vertical Aiming
	5945486	5945486	Pin—Mounting Bracket to Base
	217218	217218	Screw—Set—Pin Retaining
	5943309	5943309	Lug—Ground
	5945884	5945884	Screw—Cover Retaining
INSTALLATION PARTS			
	5942468	5942468	Pad—Phototube Unit Mounting—Oldsmobile (Metal Panel only)
	5942678	5942678	Pad—Phototube Unit Mounting—Chevrolet and Pontiac (for use with mounting bracket assembly 5945264 only)
	5946880	5946880	Pad—Phototube Unit Mounting—Buick 50-70 Series (for use with mounting bracket assembly 5945264 only)
	5946881	5946881	Pad—Phototube Unit Mounting—Buick 40-60 Series (for use with mounting bracket assembly 5945264 only)
	5942166	5942166	Plate—Phototube Unit Mounting—Oldsmobile
	5942306	5942306	Plate—Phototube Unit Mounting—Cadillac
	5944526	5944526	Plate—Phototube Unit Mounting—Chevrolet, Pontiac
	5946883	5946883	Plate—Phototube Unit Mounting—Buick—All
	5945954	5945954	Terminal—Adapter—1955 Chevrolet, Pontiac, Buick

Guide

GUIDE LAMP DIVISION

GENERAL MOTORS CORPORATION
ANDERSON, INDIANA, U.S.A.

Bulletin 6D-454
Guide Autronic-Eye
Date 2-15-55
Supplement No. 1
to
Bulletin 6D-454
dated 12-1-54

SUBJECT:

SERVICE INSTRUCTIONS—AUTRONIC-EYE® Automatic Headlight Control 12 VOLT—1955—CIRCUIT D-1

Effective with serial numbers listed below, a minor change has been made in Amplifier Wiring Circuit. The resulting circuit is designated as "Circuit D-1."

Note: Identification is shown on circuit diagram found in amplifier cover.

Car	Year	Amplifier and Phototube Unit Serial Numbers	Amplifier Unit [†] Less Wiring	Amplifier Wiring Assembly	Phototube Unit [†]	Power Relay	Auxiliary Foot Switch
CADILLAC—All	1955	From 555200001 Thru 555999999	5946698 [†]	5946603	897871 [†]	5946545	5945230
OLDSMOBILE Metal Panel	1955	From {355200001 355200001 Thru 355999999	5946697 [†]	5946572 [*]	897868 [†]	5946545	5943291
Crash Pad Panel	1955		5946697 [†]	5946572 [*]	897867 [†]	5946545	5943291
CHEVROLET	1955	From 155200001 Thru 155999999	5946698 [†]	5946885	897959 [†]	5946545	5945230

*For air conditioned cars use amplifier wiring assembly 5946605.

[†]Service replacement amplifier and phototube units will start with Serial 75520001 to 75599999 inclusive.

[†]Service replacement amplifier and phototube units will start with Serial 755320001 to 755399999 inclusive.

[†]Service replacement amplifier and phototube units will start with Serial 755120001 to 755199999 inclusive.

[†]Patent Nos. 2598420 and 2679616. Other Patents Pending.

The 47 ohm, 2 watt filament resistor, Illustration No. 14, has been removed from section one filament (pin 5) of amplifier tube. Section two filament (pin 4) of the amplifier tube, has been disconnected from the regulated 6.8 volt line, and the ground connection removed from the filament center tap (pin 9). See circuit diagrams on pages 3 and 18 of Bulletin 6D-454.)

The two filaments have been connected in series across the 12 volt line. Illustration 11 has been changed to 270,000 ohms, 2 watt and Illustration 12 has been changed to 180,000 ohms, 2 watt (Fig. A).

It is not necessary to incorporate this change in any set prior to above serial numbers.

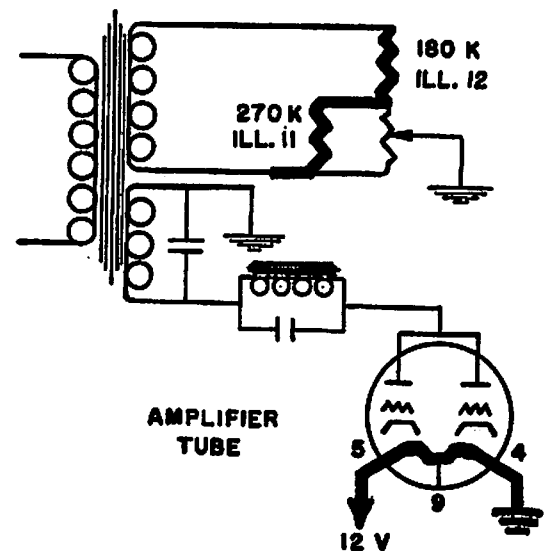

FIG. A

(Continued on Page 2)

THE FOLLOWING ERRORS SHOULD BE CORRECTED IN BULLETIN 6D-454:

1. Figure 2, pages 3 and 18, Circuit Diagram 300-800 VDC should be 300-800 VAC.
2. Page 14, Condition I, Check I—If relay is closed . . . , amplifier will keep headlamps on "Lower Beam," should read "Upper Beam."

Servicing Tips

Service Adjustments:

On "Circuit D" and "Circuit D-1" Autronic-Eye sets, the "Dim" and "Hold" sensitivity adjustments are both located on the bottom of the amplifier base and correspondingly marked on the amplifier cover. In order to provide fast and accurate sensitivity adjustments, the "Hold" sensitivity must be adjusted before the "Dim" sensitivity is adjusted. This procedure is opposite to any method used on previous models. AN ATTEMPT TO ADJUST "DIM" SENSITIVITY BEFORE "HOLD" SENSITIVITY WILL, IN MOST CASES, RESULT IN CONFUSION. For detailed adjustment procedures see page 6 of Bulletin 6D-454.

Car Battery Voltages:

In some instances, the car battery voltage is low when the headlamps are turned on with the engine off. If the "Autronic-Eye" is adjusted under these conditions, it is impossible to provide a correct sensitivity adjustment. To assure correct adjustment, the final "Dim" and "Hold" sensitivity adjustments on the car should be made with the engine running at fast idle.

This procedure should be followed in adjusting sensitivity on all "Autronic-Eye" sets.

Guide

GUIDE LAMP DIVISION
GENERAL MOTORS CORPORATION
ANDERSON, INDIANA, U.S.A.

Bulletin	6D-454
Guide Autronic-Eye	
Date	3-15-55
Supplement No. 2	
to	
Bulletin	6D-454
dated	12-1-54

SUBJECT:

SERVICE INSTRUCTIONS – AUTRONIC-EYE® Automatic Headlight Control 12 Volt – 1955 – Circuit D and D-1

Starting with Oldsmobile Serial No. 355200001, Cadillac Serial No. 555200001, and Chevrolet Serial No. 155200001, the Phototube Unit will use amber filter No. 5943350 instead of No. 5946693. (Illustration 31 — Page 20.) Filter No. 5943350 is the same as used from 1952 through 1954 and is easily recognized as darker in color than filter No. 5946693.

Service Parts List

Page 22—Illustration 31—Production and Service part No. 5946693 should be changed to No. 5943350.

"Hold" Sensitivity Adjustment

A new "Hold" sensitivity setting replaces the original setting. Previously the "Hold" sensitivity has always been adjusted to the center of the "Hold" adjustment bar (clear or tinted windshield) on both Sun Model AE and Kent-Moore Model 10 Testers. "Hold" sensitivity should now be adjusted to the right hand edge of the "Hold" adjustment bar for both testers.

"Dim" Sensitivity Adjustment

"Dim" sensitivity adjustment remains the same as before (black line).

Previous Models

The new "Hold" sensitivity setting applies to all previous models.

Servicing Tips

Locking On Low Beam

When an occasional complaint is received that second type 1955 Oldsmobile or Cadillac Autronic-Eye locks on lower beam, proceed as follows:

(Second type has both adjusting screws on the bottom of the amplifier).

1. If yellow filter No. 5946693 is installed in the Phototube Unit, it should be replaced by the darker amber filter No. 5943350. (Same as used from 1952 through 1954.)
2. Adjust "Hold" sensitivity to right hand edge of "Hold" adjustment bar (clear or tinted windshield) on the tester.
3. Adjust "Dim" sensitivity, same as before, to the black line (clear or tinted windshield).
4. Readjust vertical and horizontal aim if necessary.

Auxiliary Foot Switch

Should an owner report loss of automatic operation in either position of the Standard Foot Dimmer Switch, the rubber grommet surrounding the Auxiliary Foot Switch should be checked for clearance. Any binding action by the grommet will tend to hold it in partly depressed position. This will hold the headlamps on upper beam in the "Automatic" position of the Standard Foot Dimmer Switch.

To correct this trouble the rubber grommet should be trimmed out to allow a good clearance.

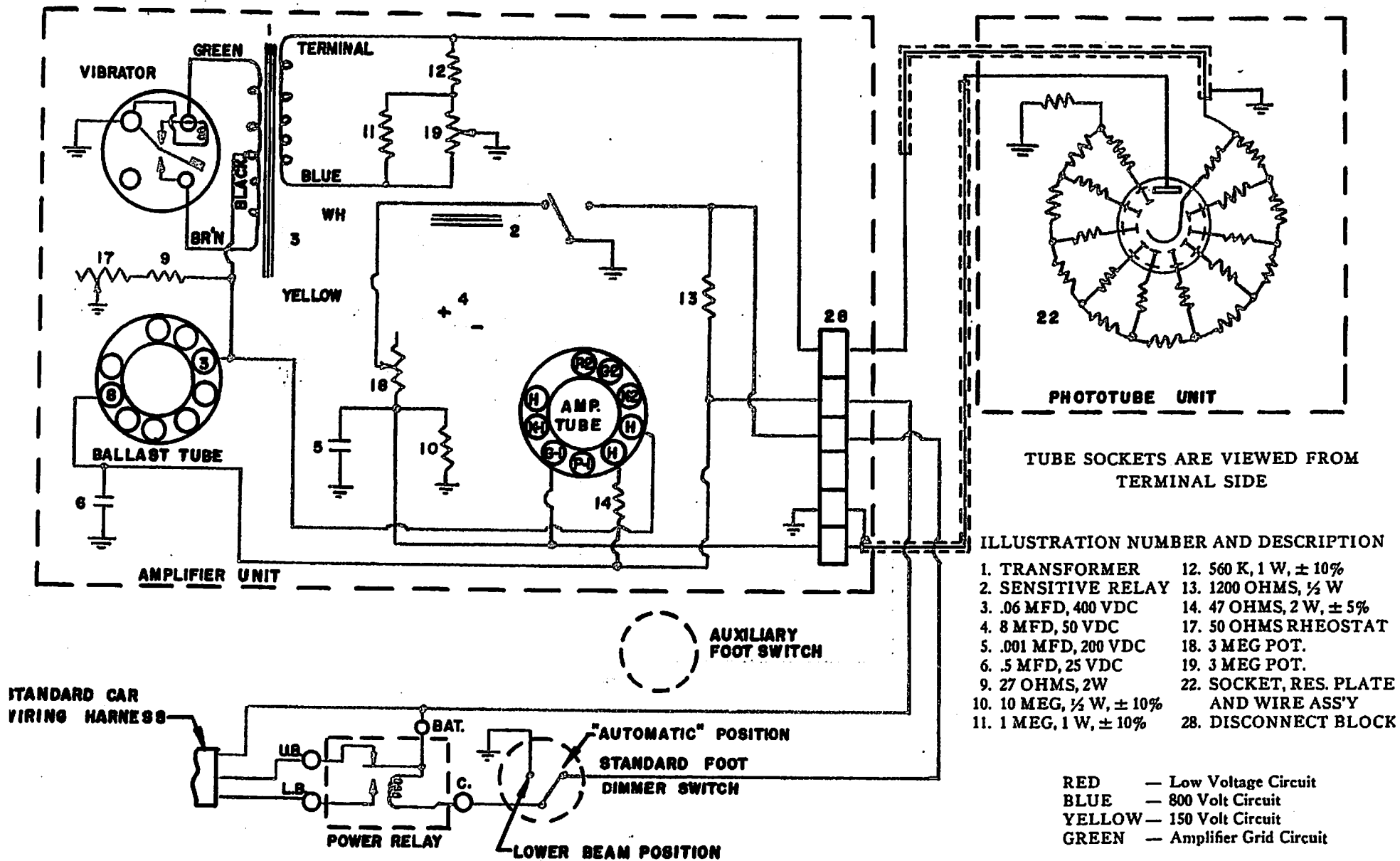

- ILLUSTRATION NUMBER AND DESCRIPTION
- | | |
|------------------------|---------------------------------------|
| 1. TRANSFORMER | 12. 560 K, 1 W, ± 10% |
| 2. SENSITIVE RELAY | 13. 1200 OHMS, ½ W |
| 3. .06 MFD, 400 VDC | 14. 47 OHMS, 2 W, ± 5% |
| 4. 8 MFD, 50 VDC | 17. 50 OHMS RHEOSTAT |
| 5. .001 MFD, 200 VDC | 18. 3 MEG POT. |
| 6. .5 MFD, 25 VDC | 19. 3 MEG POT. |
| 9. 27 OHMS, 2W | 22. SOCKET, RES. PLATE AND WIRE ASS'Y |
| 10. 10 MEG, ½ W, ± 10% | 28. DISCONNECT BLOCK |
| 11. 1 MEG, 1 W, ± 10% | |

RED — Low Voltage Circuit
 BLUE — 800 Volt Circuit
 YELLOW — 150 Volt Circuit
 GREEN — Amplifier Grid Circuit

AUTRONIC-EYE® WIRING DIAGRAM
 1955 - 12 VOLT
 CIRCUIT D

GUIDE LAMP DIVISION
 11-1-54



GUIDE "AUTRONIC EYE" Automatic Headlamp Control

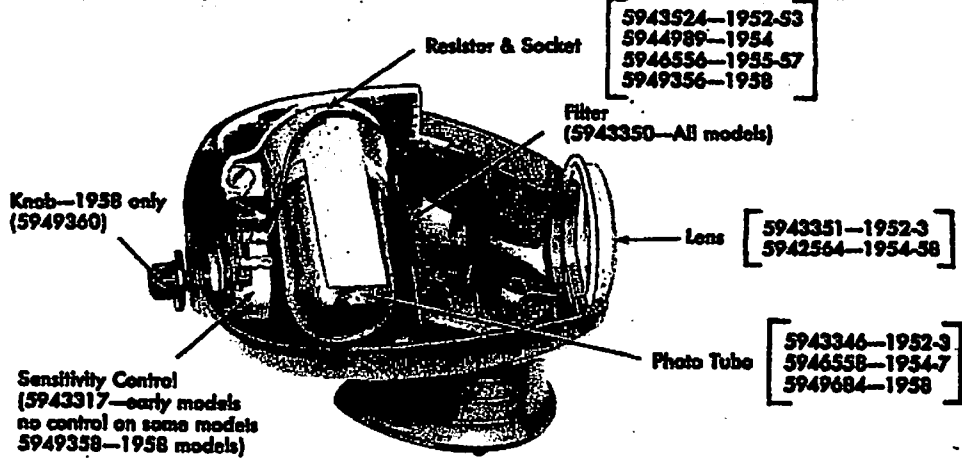

"Autronic Eye" Service Bulletin-Numbers

Description	Year	Bulletin
Lincoln Tr.....	1959	8D-489
Cadillac Tr.....	1959	8D-488
Buick Tr.....	1959	8D-487
Pontiac Tr.....	1959	8D-486
Chevrolet Tr.....	1959	8D-485
General L.V.....	1959	8D-484
Oldsmobile L.V.....	1959	8D-483
Cadillac L.V.....	1959	8D-482
Amplifier Moisture }.....	1958	8D-460
Transistor Power }.....	1958	8D-459
Oldsmobile.....	1958	8D-458
Chevrolet }.....	1958	8D-457
Pontiac }.....		
Buick.....	1958	8D-456

Refer to index page 8D-400 for older models.

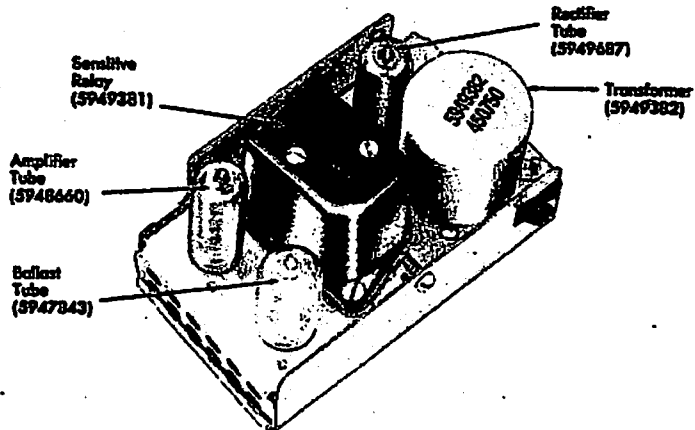

AMPLIFIER UNIT ALL EXCEPT 1958

Power Transformer
5943314-All 6 Volt Units
5943256-1953-4-12 Volt
5946488-1955-57

Balast Tube
5943335-1952
5944545-1953-4-6 Volt
5944299-1953-7-12 Volt

Amplifier Tube (5943333)

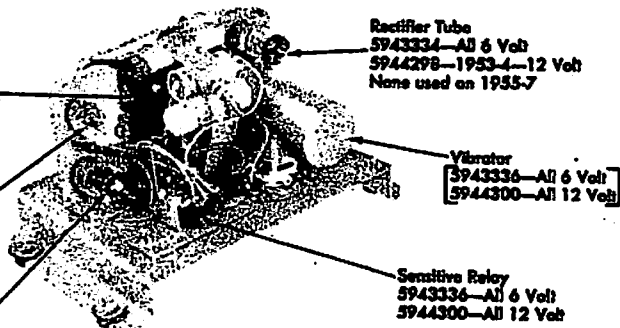

AUXILIARY FOOT SWITCHES

Part No.	Used on
5943291	Chev. 1952-3; Olds. 1952-55; Pontiac Series 2000, 1952
5949506	Cadillac 1952-3; Pontiac Series 25, 27, 1952
5945230	Chev. 1954, 56; Cadillac 1954-55

All others part of Dimmer Switch

POWER RELAYS

Part No.	Used on
5945188	All 6 Volt
5945189	1953-54 & 1958
5946845	1955-57

